



IP 50-80-120-180 XP BA

impastatrici per carne
meat mixers



- Moderno design e robusta struttura in AISI 304 a forte spessore.
- Vasca ribaltabile con sistema di blocco automatico e blocco di sicurezza.
- Ruote inox girevoli e con freno (2).
- Sistema classico con 2 alberi affiancati.
- Pale in acciaio inox AISI 304 facilmente rimovibili senza attrezzi.
- Carter con protezione totale della parte riduttori/ comandi.
- Riduttore a bagno d'olio con ingranaggi elicoidali temperati e rettificati.
- Protezione dai liquidi a doppio paraolio: su vasca e su riduttore.
- Sistema di controllo con comandi in acciaio inox IP 67 di serie:
 - marcia avanti e indietro
 - automatismo con autospegnimento
 - automatismo con inversione
- Coperchio in acciaio inox con micro di sicurezza.
- Carico minimo 40% capienza vasca.
- Ideale anche per impasti duri e insalate.

Opzionale:

- Tramoggia aggiunta ingredienti.



IP 180 XP BA

- *Modern design and strong AISI 304 stainless steel construction.*
- *Tilting tank with automatic locking system and safety lock.*
- *Stainless steel swivel wheels with lock (2).*
- *Two mixing arms system.*
- *Removable AISI 304 stainless steel mixing arms (no tools required).*
- *Total protection of gear box/control panel.*
- *Oil bath reducer with hardened and ground helical gears.*
- *Double seal on tank and gear box.*
- *Stainless steel IP 67 controls:*
 - *Forward and backward*
 - *auto-off feature*
 - *auto-function with reverse*
- *Stainless steel cover with safety microswitch.*
- *Minimum loading required: 40% max capacity.*
- *Perfect for hard mix and salad.*

Optional:

- *Feeding tray to add ingredients.*



Ribaltamento vasca
Tank overturn

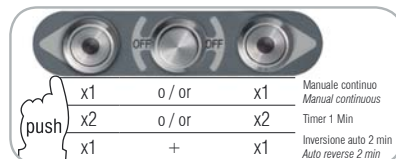

Sistema di controllo
Control system

Pale facilmente rimovibili
Removable mixing arms

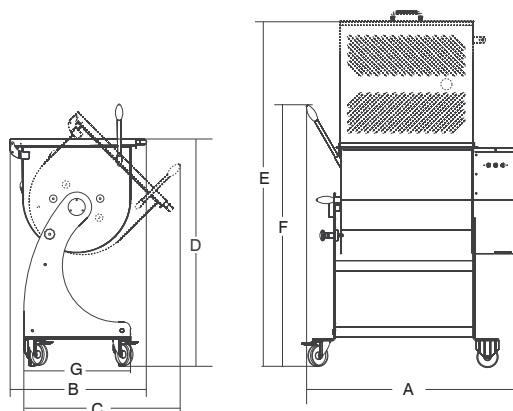

					A	B	C	D	E	F	G			
	watt/HP		mm	lt/kg	mm	mm	mm	mm	mm	mm	mm	kg	mm	kg
IP 50 XP BA	1ph 370/0.5(x2) 3ph 530/0.7(x2)	1ph/3ph	420x500	88/50	810	630	730	1030	1617	1220	500	85	1200x670x1300	105
IP 80 XP BA	1ph 370/0.5(x2) 3ph 530/0.7(x2)	1ph/3ph	620x500	110/88	1000	630	730	1030	1617	1220	500	90	1200x670x1300	110
IP 120 XP BA	1ph 750/1(x2) 3ph 1.100/1.5(x2)	1ph/3ph	660x550	163/120	1092	700	855	1030	1717	1209	620	138	1450x750x1300	167
IP 180 XP BA	1ph 750/1(x2) 3ph 1.100/1.5(x2)	1ph/3ph	995x550	250/180	1422	700	855	1030	1717	1209	620	152	1450x750x1300	182



IP 50 XP BA



IP 80 XP BA



IP 120 XP BA