

G-325 model



Dimensions DATA IN mm

A	320
B	400
C	356
D	116

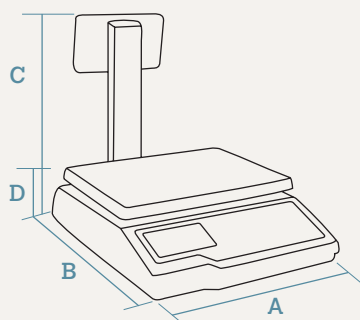

Plate (stainless steel): L305 x W235 mm



LCD SEGMENT DISPLAY



UP TO 100 PLUs



RS-232



INTERNAL RECHARGEABLE BATTERY IN G-325 B F/P



METROLOGICAL VERIFICATION OPTIONAL

Models

	Displays	PLUs	Direct PLUs	Communication protocols	Power	Capacity / Accuracy	Reference
G-325 F/P	LCD Segment	100	9x2	Up to 100	Mains	6 kg / 2 g - 15 kg / 5 g	70321S00NE_ _
G-325 B F/P	LCD Segment	100	9x2	Up to 100	Mains / battery	6 kg / 2 g - 15 kg / 5 g	70321S02NE_ _

Characteristics and functionality

Main characteristics

- Price computing electronic scale without printer.
- RS-232 interface: PC upgradeable firmware and communication protocols.
- Internal rechargeable battery:
 - Up to 120 hours of life with completely charged battery and back lighting disconnected (approximate data).
- Valid for legal metrology.

Features

- EAN heading programming (according to communication protocol).
- Tare, fix tare and manual zero.
- Fix price: to operate several times with the same article.
- Display of price in a secondary currency.
- Energy saving via programmable on and off back lighting switching and automatic disconnection.

Capacity / Accuracy

- Multirange (3,000 divisions): 6 kg / 2 g - 15 kg / 5 g.
- Optional:
 - Multirange (3,000 divisions): 15 kg / 5 g - 30 kg / 10 g.

Available formats

- Flat and pole in the same scale: An easy to set up pole is included.

Construction

- Structure:
 - ABS plastic casing.
- Display:
 - 5 digits backlit LCD segment display in vendor and buyer side.
 - Shows weight, price / kg and total.
- Keypad with 32-keys.
- Stainless steel flat plate.

Communication to PC / POS / ECR

- RS-232 interface.
- Communication protocols available for the main POS and ECR in the market.
- Multi-protocol models: communication protocol is selected in the scale (40 protocols available). More protocols can be added from PC by telecharge (maximum: 60 protocols more).

Power supply

- Mains: 220 VAC with AC/DC 12 V / 500 mA adapter.
- 6 VDC / 4.5 Ah rechargeable internal battery available (only in G-325 B F/P) and connection to external battery.

Options

Option	Characteristics	Reference
Capacity 15 kg / 5 g - 30 kg / 10 g	Multirange (3,000 divisions).	...F__ (*)
Metrological verification (M)	According to EU weighing directives. (See section on equipment metrological verification).	Consult

(*) The scale references with this capacity are obtained by replacing the last characters of the reference for the standard scale with the indicated ending.

Accessories

Italian plate

L357 x W235 x H55 mm.

The Italian plate is placed on the flat plate. A new weight adjustment might be necessary. Consult.



Ref: BCR71

Note:

- The references correspond to standard models: Black ABS plastic casing, LCD segment display, flat stainless steel plate and RS-232 communications. Capacity/Accuracy: 6 kg / 2 g - 15 kg / 2 g.